

MBMTG820H-BK



CARACTERÍSTICAS

MODELO	MBMTG820H-BK	
Código EAN	6944271677568	
Tipo	Integrable	
Capacidad	L	20
Tipo de control	Digital, mando giratorio escamoteable + panel de control táctil	
Potencia Microondas	W	800
Potencia Grill	W	1000
Tensión / Alimentación	V/Hz	230/50
Color panel de control	Negro / Inox	
Color exterior	Cristal negro	
Tipo apertura puerta	Tecla push	
Plato giratorio	Sí	
Diámetro plato giratorio	mm	245
Temporizador	min	0-95
Funciones	7	
Cocción automática	8 menús	
Cocción Inverter	No	
Dimensiones y Peso - Neto	Ancho/Alto/fondo	595 / 388 / 320 mm - 14,5 Kilos
Dimensiones y Peso (embalaje) - Bruto	Ancho/Alto/fondo	650 / 446 / 405 mm - 16,5 Kilos

NOTAS:

- (1) Los datos y especificaciones presentes en esta ficha pueden variar sin previo aviso.
- (2) Las imágenes de esta ficha son de carácter orientativo, pudiendo ser diferentes a la máquina final.

MBMTG820HBK FORNO MICROONDE INC. 20 LITRI NERO MIDEA

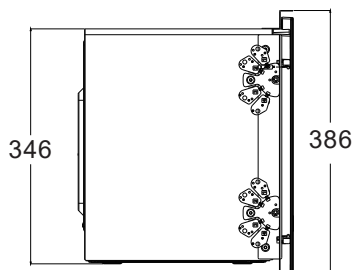
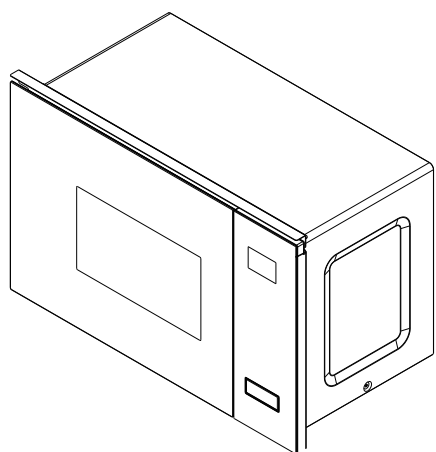
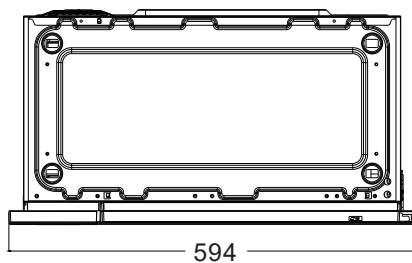
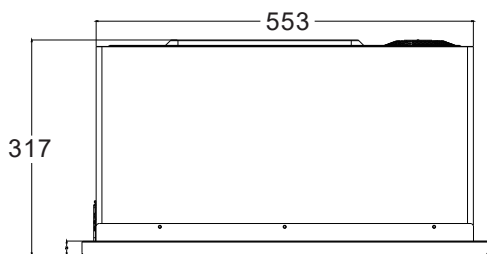
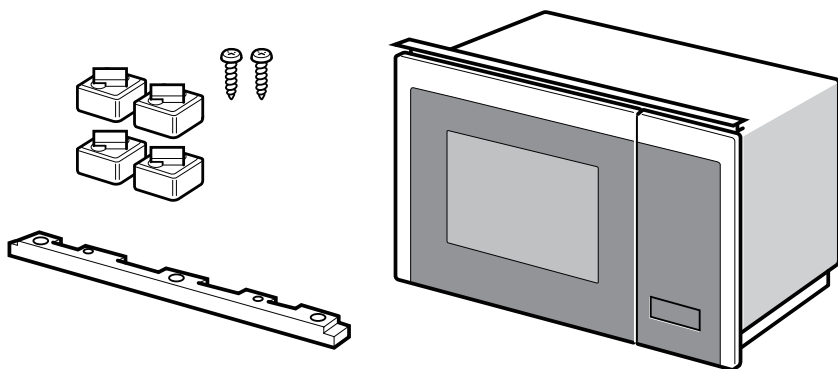

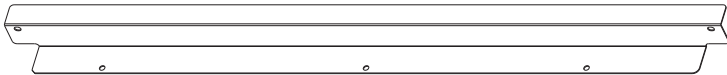
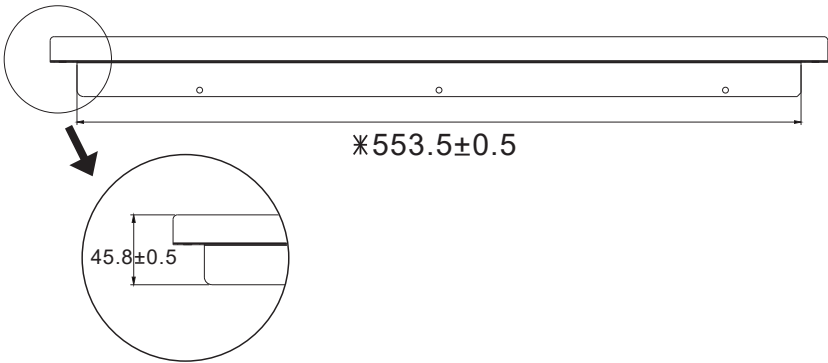
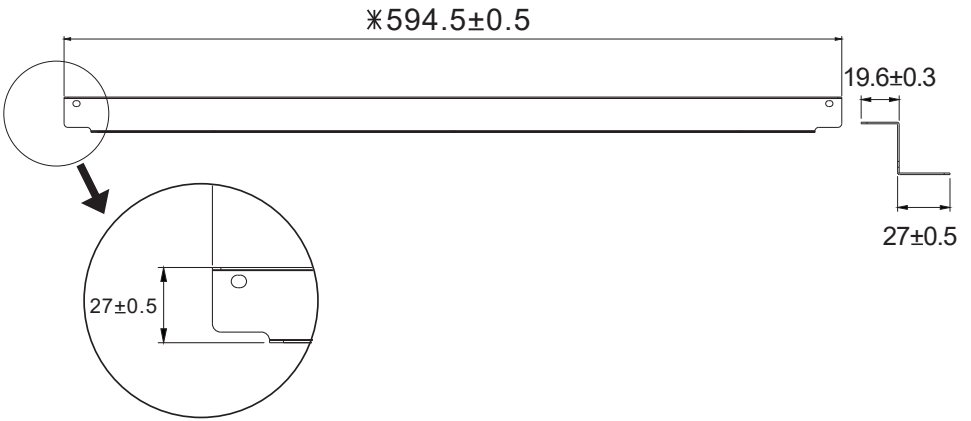

1

A

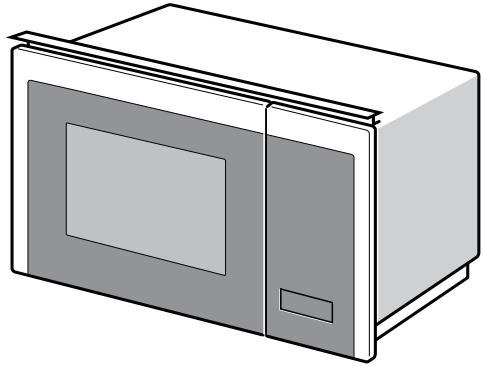
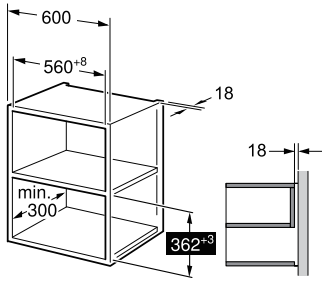

B

